

Stingray



Wheel Loader
XG918 II

Excellent Performance

- ***Powerful Cummins Engine.***
- ***Bosch Rexroth Hydraulics.***
- ***Ergonomical Joystick controls.***
- ***Spacious modern cabin with superb visibility.***
- ***Heated KAB comfort seating.***
- ***Automatic bucket levelling.***
- ***Electronic gear change.***
- ***Adjustable steering column.***
- ***4 in 1 bucket with hydraulic Quick Hitch (optional).***



- ✓ Panoramic drivers view for improved visibility and safer operations.
- ✓ Ergonomical Bosch-Rexroth pilot joystick controls with automatic bucket self levelling.
- ✓ KAB heated fully adjustable suspension driver seat for ultimate comfort also keeps driver more productive and less fatigued.



SPACIOUS OPERATING STATION FOR SUPERIOR COMFORT

- ✓ Fully adjustable steering column comprised of multi-functional instrument panel and easy to read illuminated gauges and indicators keeping the operator informed of system conditions.



- ✓ Factory Air Con and heating as standard.



- ✓ Standard rear view camera and LCD monitor adding to operator and bystander safety.

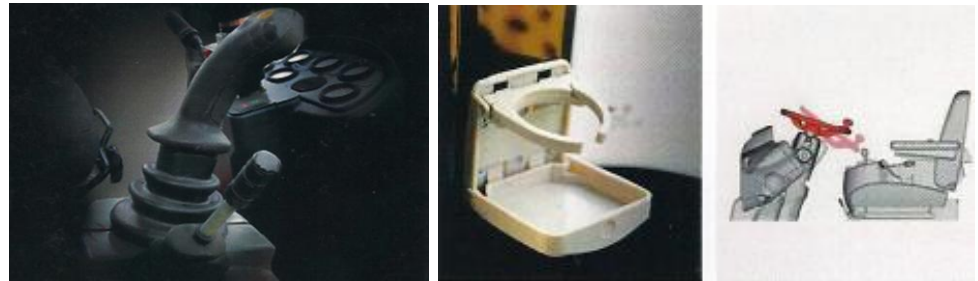

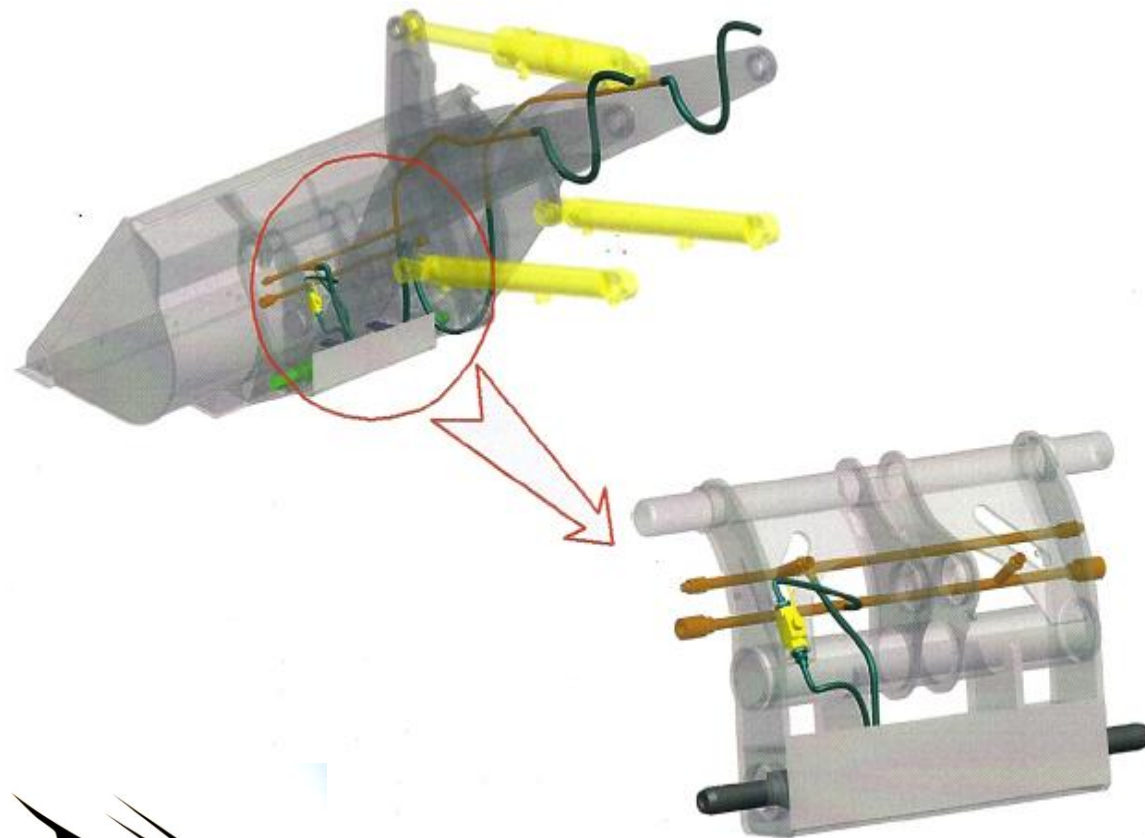

- ✓ Optional hydraulic quick hitch device which can satisfy multiple purposes for customers with a comprehensive range of tool attachments.
- ✓ Heavy duty loader arm assembly designed to withstand heavy duty applications.

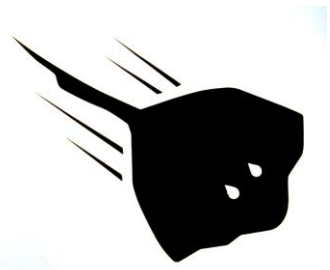

- ✓ Optional 4 in 1 bucket.
- ✓ Heavy duty Z Bar linkage for increased performance and maximum break out and tilt force.



Stingray